



# London Borough of Hounslow

## Deposited Documents – Reference TMO/P046/23

Held on deposit online [https://www.hounslow.gov.uk/downloads/20165/traffic\\_notices](https://www.hounslow.gov.uk/downloads/20165/traffic_notices)

Placed on deposit on Friday, 1 December 2023

End of Consultation period is Friday, 22 December 2023

## Proposed waiting restrictions, St Mary's Drive, Feltham

### Contents:

1. **Notice of Intent dated 1 December 2023**
2. **Proposed Traffic Management Orders**
  - A. The London Borough of Hounslow (Waiting and Loading Restriction) (Amendment No.\*\*\*) Order 20\*\*
3. **Statement of Reasons**
4. **Plan**
5. **Existing Traffic Management Orders**
  - A. The London Borough of Hounslow (Waiting and Loading Restriction) Order 2008 (Extract of Articles only)

Any queries regarding these deposited documents should be sent by email to [trafficorders@hounslow.gov.uk](mailto:trafficorders@hounslow.gov.uk) or alternatively a voicemail can be left on extension 3322.

## **Proposed waiting restrictions, St Mary's Drive, Feltham**

### **A. The London Borough of Hounslow (Waiting and Loading Restriction) (Amendment No.\*\*\*) Order 20\*\***

1. The London Borough of Hounslow proposes to make the above Order under the Road Traffic Regulation Act 1984.
2. The general effect of the Order would be to introduce “no waiting at any time” restrictions on the north-west side of St Mary's Drive between its junction with Hatton Road and opposite of the common boundary of No.9 and No.10 St Mary's Drive.
3. Documents giving further information of the proposed Order can be viewed for a period of 21 days from the date of this Notice online at [hounslow.gov.uk](https://www.hounslow.gov.uk) by typing in the term “traffic notices” in the search bar.
4. Any person wishing to object to the proposed Order should send a statement in writing, stating the grounds of the objection, to the Assistant Director of Traffic, Transport & Parking, Hounslow Council, Hounslow House, 7 Bath Road, Hounslow, Middlesex TW3 3EB or by email to [trafficorders@hounslow.gov.uk](mailto:trafficorders@hounslow.gov.uk) quoting the reference TMO/P046/23, to be received by no later than Friday, 22 December 2023.

Dated 1 December 2023

Jefferson Nwokeoma  
Assistant Director Traffic, & Transport & Parking

# Traffic Management Order

20\*\* No.\*\*

---

The London Borough of Hounslow (Waiting and Loading Restriction) (Amendment No.\*\*\*) Order 20\*\*

Made on \*\* \*\*\*\*\* 20\*\*

Coming into operation on \*\* \*\*\*\*\* 20\*\*

---

The Council of the London Borough of Hounslow, after consulting the Commissioner of Police of the Metropolis, in exercise of the powers conferred by the Road Traffic Regulation Act 1984<sup>1</sup> as amended, and of all other enabling powers hereby make the following Order:

- 1 This Order shall come into operation on \*\* \*\*\*\*\* 20\*\* and may be cited as the London Borough of Hounslow (Waiting and Loading Restriction) (Amendment No.\*\*\*) Order 20\*\*.
- 2 Without prejudice to the validity of anything done or to any liability incurred in respect of any act or omission before the coming into operation of this Order, The Hounslow (Waiting and Loading Restriction) Order 2008<sup>2</sup> shall have effect as though:
  - (a) the items numbered 498 in Schedule 1 to that Order were substituted with those items similarly numbered and set out in the Schedule to this Order.

Dated this \*\*\*\*\* day of \*\*\*\*\* 20\*\*

Assistant Director for Traffic, Transport & Parking  
(the officer appointed for the purpose)

---

<sup>1</sup> 1984 c.27

<sup>2</sup> LBH 2008/24

## Schedule

1 Street Reference	2 Item Number	3 Street	4 Prescribed hours - see Schedule 3
498	ai	St Mary's Drive, Feltham, Hounslow, north-west side, between the north-western kerb-line of Hatton Road, Feltham, and a point opposite of the common boundary of No.9 & No.10 St Mary's	A
498	bi	St Marys Drive, Feltham, Hounslow, south-west side, from the junction with Hatton Road to a point 19 metres east of the common boundary of Nos. 1 & 3 St Mary's Crescent	A

---

### EXPLANATORY NOTE

(This Note is not part of the Order, but is intended to indicate its general purport.)

This Order further amends the Hounslow (Waiting and Loading Restriction) Order 2008 by amending waiting restrictions in St Mary's Road, Feltham, to maintain access to St Mary's Drive and improve road safety.



**London Borough  
of Hounslow**

## **Statement of Reasons**

### **Proposed no waiting “at any time” restrictions in St Mary’s Drive, Feltham**

The Council is proposing to introduce ‘at any time’ waiting restrictions in St Mary’s Drive, Feltham to maintain access and improve road safety.

S278 Key	
Item	Description
	Existing Level BOK = Bottom of Kerb TOK = Top of Kerb DK = Drop Kerb
	Proposed Level BOK = Bottom of Kerb TOK = Top of Kerb DK = Drop Kerb
	Site boundary
	Proposed S278 boundary
	Yellow lining to Traffic Signs Manual
	White lining to Traffic Signs Manual

**General Notes:**

- Do not scale from this drawing manually or electronically. Written permission must be obtained from SD Structures prior to scaling.
- Contact SD Structures in the event of any discrepancies between findings on site and these drawings.
- This drawing is also to be read in conjunction with all relevant Architect's, Engineer's and Specialist's drawings and specifications.
- 3D views are indicative only and any conflicting 2D information should take precedence. If in doubt contact SD Structures prior to starting work.
- All work is to be carried out in accordance with the relevant British Standards, European norms, codes of practice and building practice.
- The Contractor shall obtain licences from the Highway Authority prior to carrying out any workings within the existing Public Highway.

**Roadways and Surfacing - Notes:**

- General Site Notes**
  - The site shall be handed over from the demolition contractor with a minimum CBR of 2.5% under road locations.
  - Prior to commencement of works, the contractor shall liaise with all relevant authorities and obtain their requirements for method of working. The contractor shall liaise with all relevant authorities to locate, protect and where necessary divert all existing services affected by the works.
- Existing Roadways and Surfaces**
  - Where the proposed road lies into the existing roadway or surface, kerbing and edgings shall result in a smooth horizontal and vertical alignment
- Road Formations**
  - The road formation shall be the surface obtained after completion of any earthworks.
  - Formations, immediately before being covered with sub-base or road base material, shall be clean, free from mud and slurry and properly shaped and compacted to an even and uniform surface.
  - The preparation and surface treatment of formations shall be carried out after the reinstatement of any excavations for services.
  - The formation shall be compacted so that the dry density of the upper 150 mm of the ground or fill is less than 95% of the maximum dry density, determined in accordance with section 4 of BS 1377-4. Where the formation is in natural ground, the compaction shall, whenever possible, be carried out at or near the natural moisture of the ground.
- Sub-Base Construction**
  - Within 48 hours of completion of a road formation, granular sub-base material shall be spread and compacted to the required thickness. The sub-base shall be protected from deterioration due to ingress of water, the adverse effects of weather and the use of construction equipment.
  - Compaction shall be carried out in accordance with the relevant highway reinstatement specification.
- Laying Hot Rolled Asphalt**
  - Transportation, laying and compaction of hot rolled asphalt shall be carried out in accordance with the relevant provisions of BS 594987.
  - Where laying against an exposed edge, the joint shall be treated with an application of bitumen conforming to BS EN 12591 grade 100/150.
- Laying Kerbs and Channels**
  - Kerbs, edgings, channels and quadrants shall be laid and bedded on a layer of class M12 mortar, either on the concrete carriageway or on a Gen3 concrete foundation, as described in the contract. They shall be buttjointed, except where they are laid on concrete carriageways. They shall be provided with joints coincident with the carriageway movement joints, of width and with filler identical to that used in the carriageway joints. All kerbs shall be backed with Gen3 concrete.
  - For radii of 12 m or less, kerbs and channels of the appropriate radius shall be used.
  - Alignment of kerbs and channels shall not deviate by more than 10 mm from that described in the contract, with no lipping of visible faces.
- Tolerances for Finished Carriageway Surfaces**
  - Finished surfaces at each stage of road construction shall not vary from the levels described in the contract by more than the following permissible tolerances:
 

7.1.1. Formation and sub-base	Permissible tolerance (mm) +10, -30
7.1.2. Base course	Permissible tolerance (mm) +15, -15
7.1.3. Surface course	Permissible tolerance (mm) +6, -6
  - The combination of permitted tolerances in the levels of different pavement courses shall not result in a reduction in thickness of the pavement, excluding the sub-base, by more than 15 mm from the specified thickness, nor a reduction in the thickness of the bituminous wearing course by more than 5mm from that specified, and the maximum allowable irregularity of the wearing surface below a 3 m straight edge shall be 3mm.
  - Combinations of reverse tolerances shall not result in ponding of surface water.
- Lining and Signage**
  - Permanent road markings shall be applied, in accordance with BS 3262-3.
  - Permanent road markings shall be in accordance with the Traffic Signs Manual.

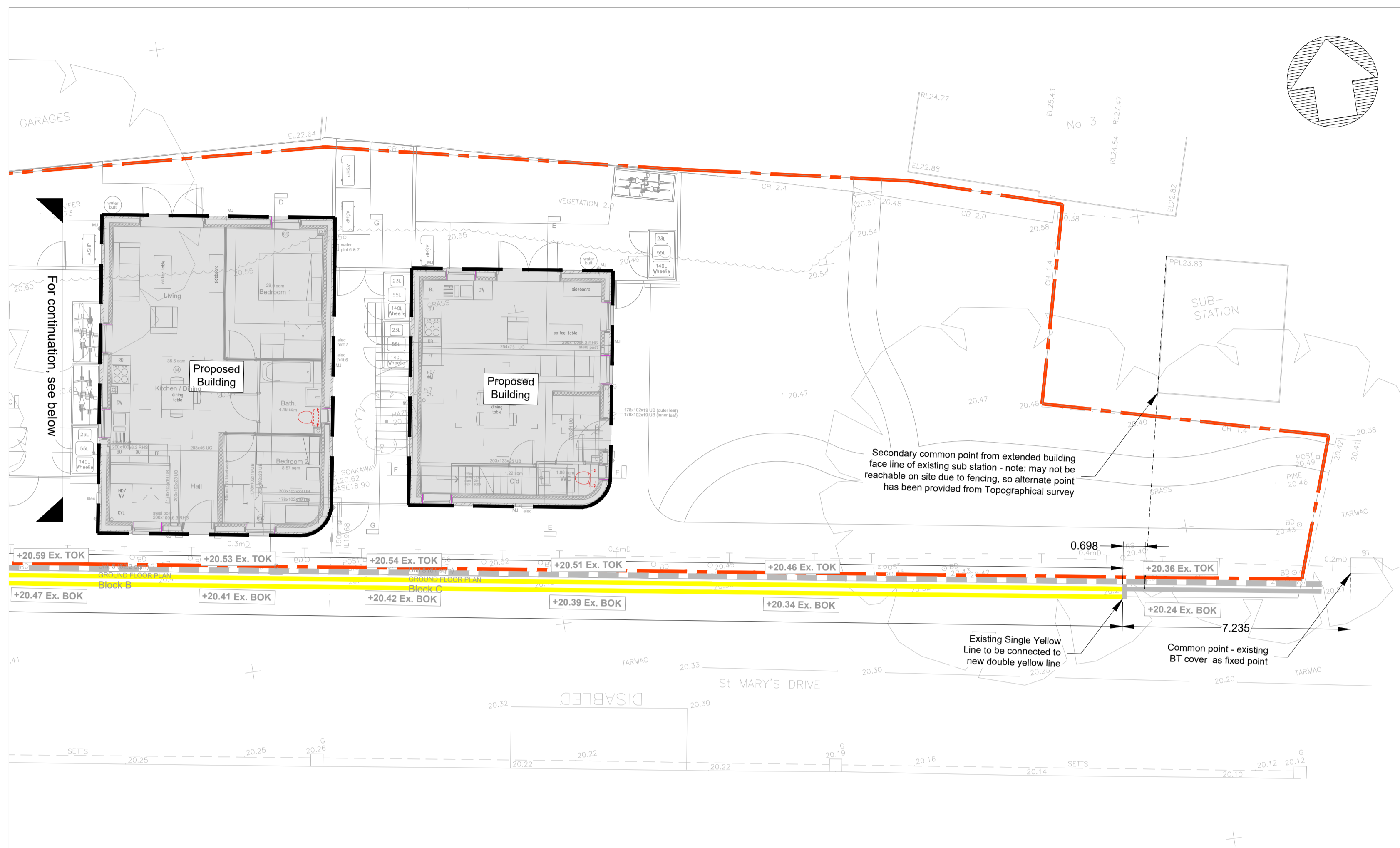

No CBR testing has been undertaken of current, so a design value of 2% has been assumed, which is to be confirmed on site. Once testing has been undertaken, Contractor to inform design team if excavated strata differs from that identified in the soils / permeability reports.

All material within 450mm of the finished ground must not be frost susceptible.

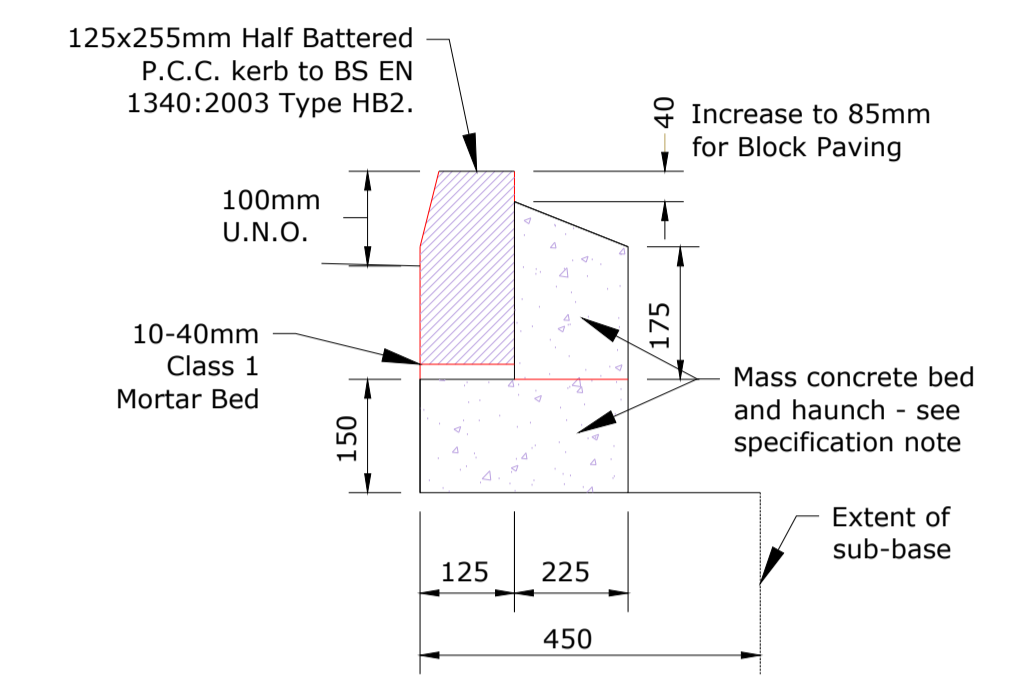

**Kerb Type HB2**

**Kerb Notes**

- For kerbs bedding and haunching concrete grade, see specification note.
- Mortar bed may be omitted if kerbs are laid directly onto wet concrete bed. Haunching to be placed within one hour of laying the bed.
- For radii up to 12.2m appropriate radius kerbs to be used, radii above 12.2m to be achieved by using standard straight kerbs.
- All kerbs and edgings to be manufactured in accordance with BS EN 1343.

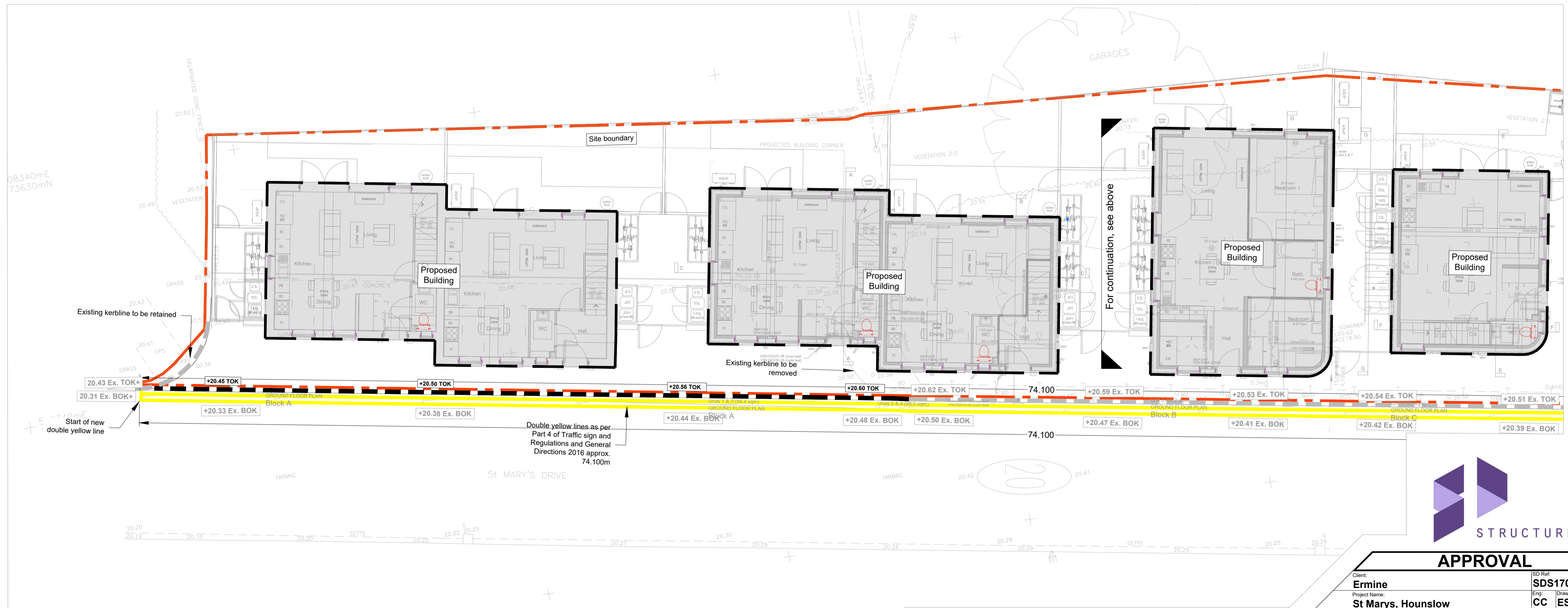

Rev	Amendment	Date	Drawn	Eng	Scale
P03	Common points added	28/11/2023	ES	CC	
P02	Length of double yellow shown	16/11/2023	ES	CC	
P01	Issued for approval	24/05/2023	ES	CC	

**SD STRUCTURES**

**APPROVAL**

Client:	<b>Ermine</b>	SD Ref:	<b>SDS1703</b>
Project Name:	<b>St Marys, Hounslow</b>	Proj. Title:	<b>CC ES</b>
Drawing Title:	<b>Proposed S278 Layout</b>		

Proj: **1703-SDS-00-XX-DR-C-4000**      Status: **P03**